

ENDON®

Swayze Semi-Flush Light Fitting

INSTRUCTION MANUAL

Safety Warnings

- These products are only suitable for connection to a 240V~50Hz supply in accordance with current IEE wiring Regulations and should be installed in accordance with local Building Regulations and are for Domestic ceiling use only. They are not suitable for a Bathroom location.
- Before installing your light fitting always switch off the mains supply and remove the appropriate fuse or switch off the appropriate circuit breaker before commencing installation.
- This is a Class II, Double Insulated product  This Fitting does not require an Earth, and Live or Neutral **must not** be connected to Earth. The terminal blocks are supplied according to requirements of the fitting.
- Never fit bulbs of a higher wattage than those specified on the label (as these may cause overheating and damage the fitting).
- If you are in any doubt about your competence please consult a qualified electrician.
- This product contains non-replaceable LEDs. Do not stare directly into the LED beam.
- If any modification is made it will invalidate the warranty and may render the product unsafe.

Care Information

Allow 10 minutes to cool before replacing, adjusting or cleaning.

Clean with a dry cloth only. Do not use liquid or abrasive cleaners on this product.

Assembly/ User Instructions

Before you start

Please read these instructions carefully before fitting and retain for reference.

Check the packaging and make sure that you have all the required parts.

Follow each assembly step in order to prevent incorrect assembly.

Ensure that the product is fully assembled as illustrated before use.

The Light pack contains:

Light fitting.

Terminal connection block(s).

Fixing pack.

The following tools may be required:

Selection of cross and flat head screwdrivers.

Electric drill and assorted drill bits.

Wire strippers.

Electrical insulation tape.

Allen Keys

These assembly diagrams are intended as a guide – if in doubt consult a qualified electrician.

Assembly/ User Instructions Continued

1. Decide on the position of the light fitting / or remove existing light fitting. Take a note of the position of the electrical connections. Ensure there is a solid mounting surface, preferably a wooden joist or joist bridge to support the weight of the light fitting.
2. Remove the four side screws (D) and retain the screws for re-use. Use the fixing bracket (B) as a template to mark the screw holes. Mark the screw holes and secure to the ceiling with appropriate screw fixings (A).
3. Support your fitting and connect the house wiring to the terminal block (C) inside insulated terminal box – see expanded wiring details below. **NOTE: This is a Class II fitting and must not be earthed.** If you have any earth cables make sure that they are connected to each other – to maintain earth continuity throughout your property – and wrap the earth terminal and connections in 2 layers of good quality insulation tape and keep them away from the terminal connections of the fitting. The 'loose' terminal block connector supplied can be used for the "loop" wires of the "Ring Circuit". There may be more than one set of cables in the "loop" connections. This terminal should be outside the fitting and wrapped in 2 layers of good quality insulation tape. **If there is a "Ring Circuit" and you do not understand the connections you must consult an electrician.**
4. Secure the ceiling cup over the bracket by using the screws (D) removed in Point 2.
5. Turn on the power and test.

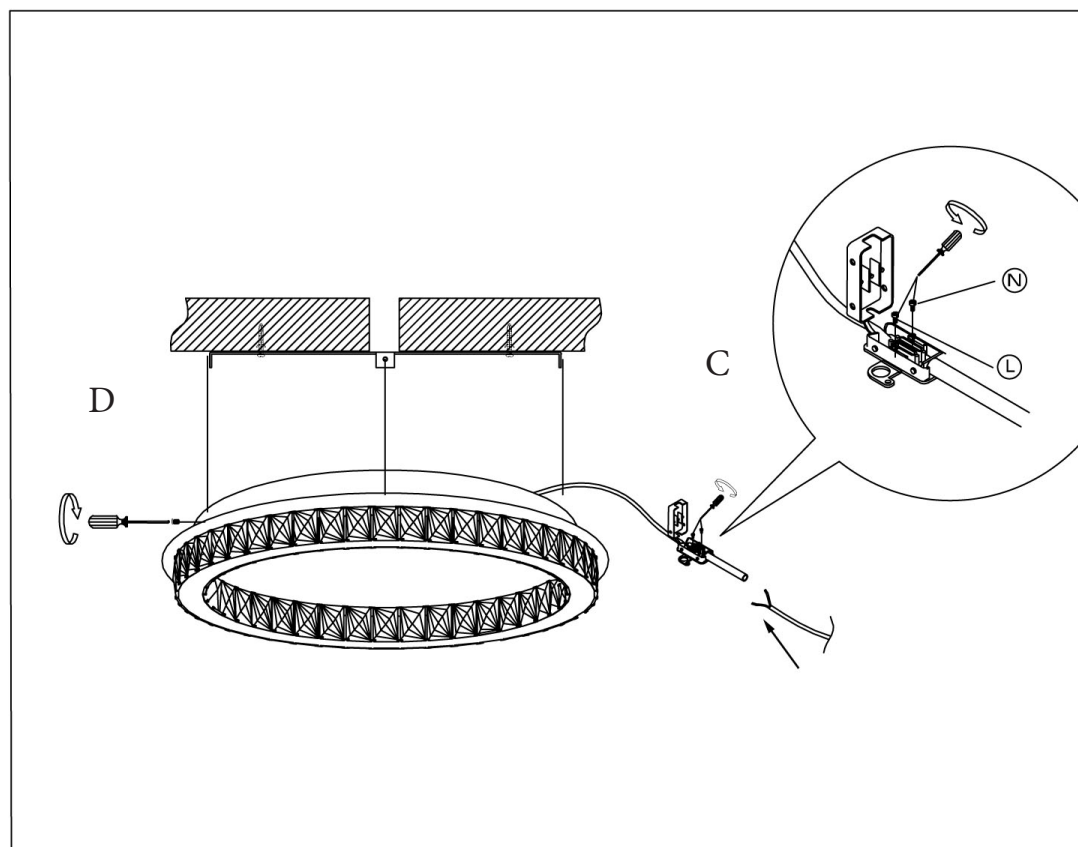
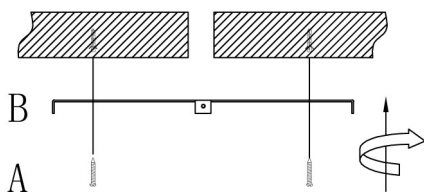

C. Wiring Diagram

