

Installation and Safety Instructions

Table Light

Safety Warnings

These instructions are for your safety. Please read through them thoroughly before use and retain them for future reference. If you are in any doubt about installing this product, consult a qualified electrician.

This product is rated IP44(definition e.g. splash proof / rain proof etc). Ensure that the screws and cable entry points are sealed to maintain the IP rating of the product.

Under no circumstances must this lamp be covered with any material as this could pose a safety hazard. This product is not suitable for persons under 14 years of age.

The battery must not be opened, destroyed or incinerated. In the unlikely event that the battery needs replacing - only use a battery of the same type and specification.

The solar panel has an integrated daylight sensor -enabling the light to come on at dusk and switch off at dawn. Ensure the product is located in a sunny position to ensure effective recharging of the battery.

To test the light and check if it is switched on, cover the solar panel and the light should operate. Initial charging for 1-2 days may be necessary.

This product may contain delicate parts – be careful during handling and maintenance to avoid breakage.

This is a touch lamp ON/OFF, touch the button to turn on. Touch again to make it brighter, brightest, and then off again.

Never put anything on the product or hang anything on any part of this product.

Waste electrical products should not be disposed of with household waste. Please recycle where facilities exist. Check with your Local Authority or local store for recycling advice..

Care and maintenance

Clean with a dry cloth only. Do not use liquid or abrasive cleaners on this product.

Troubleshooting

If you have any doubt about installation/use of this product, consult a qualified electrician.

Assembly Instructions

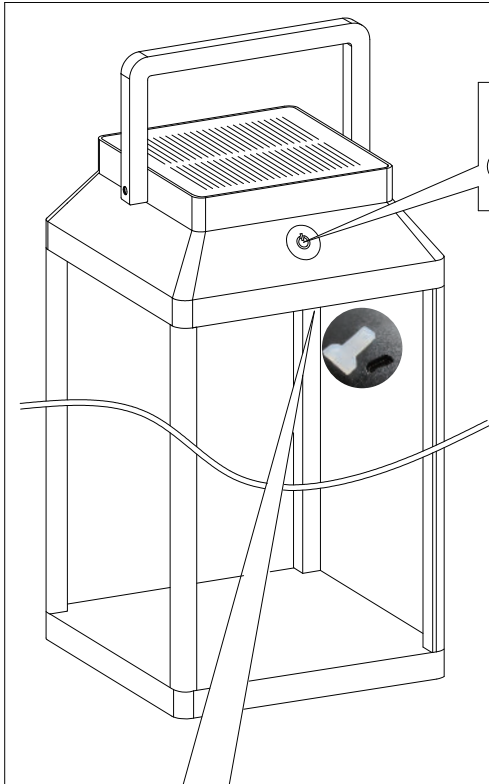

1 CLICK
20 LUMEN
3"

NOTE - This product will only illuminate at dusk. It will not be able to be operated during daylight.

Press and hold the switch for 3 seconds to turn on, the product will stay on at 20Lm

2 CLICK
90 LUMEN
1"

After mode 1, touch the switch make it brighter, the product will stay on at 90Lm

3 CLICK
230 LUMEN
1"

After mode 2, touch the switch make it brighter, the product will stay on at 230Lm

4 CLICK
OFF
3"

Press and hold the switch for 3 seconds to turn off.

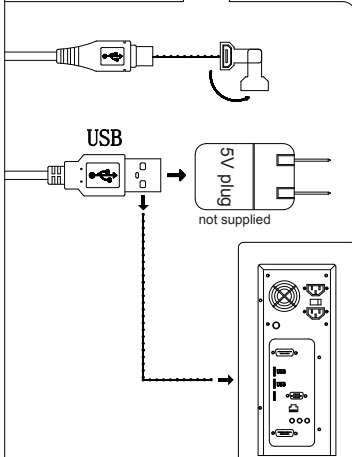

This product can also be charged using the supplied USB cable. Please note - this cable is for charging the product, not to charge other items.

Solar Charge Time - 13-15hrs
USB Charge Time - 6-7hrs
Functional Time - 8-9hrs.

Battery Replacement

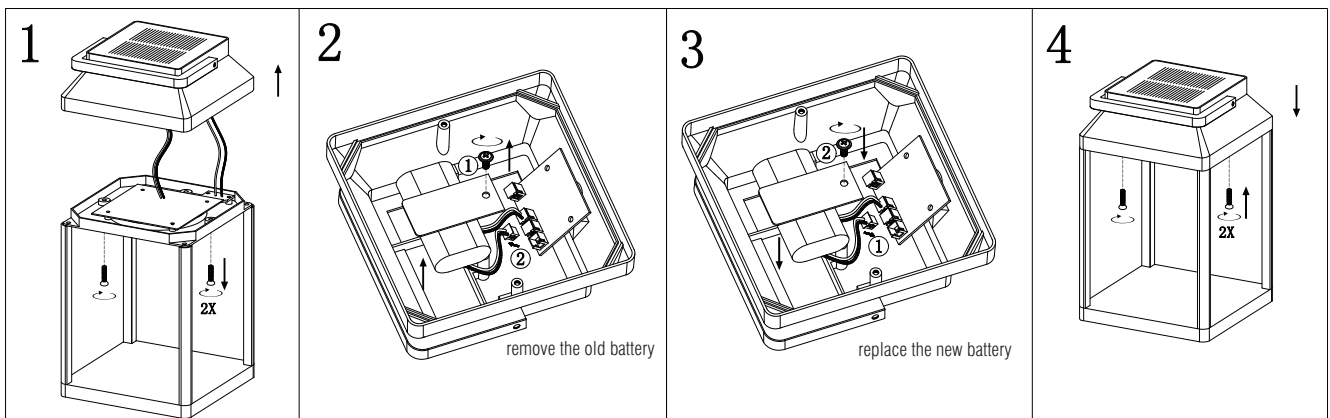

- (EN) Scan QR code for multi-language
- (FR) Scannez le code QR pour plusieurs langues
- (ES) Escanee el código QR para varios idiomas
- (PL) Zeskanuj kod QR dla wielu języków
- (DE) Scannen Sie den QR-Code nach mehreren Sprachen
- (IT) Scansiona il codice QR per multilingua



UK Manufacturer: BH17 7BY
EU Manufacturer: 1 Gnarrenburg, 27442